



Manufacturer of PCB Terminal Blocks, Fuse Holders, Barrier Terminals, & Switches

## Screw Type (Cage-Clamp Design) Connectors

### Series 50

[Model : 50/2, 50/3]

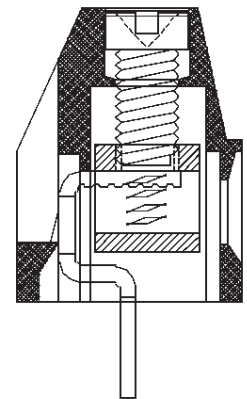
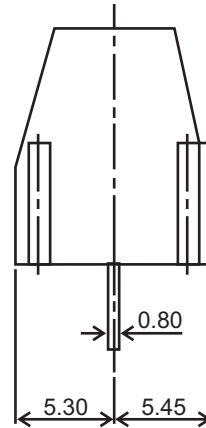
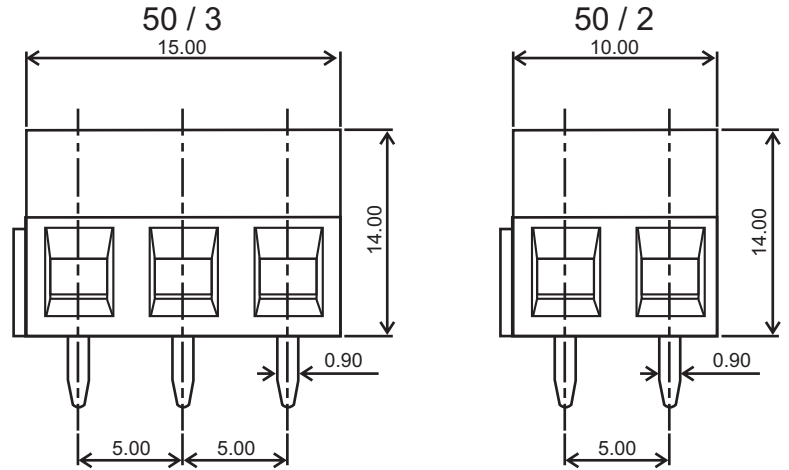

### TECHNICAL SPECIFICATIONS :

<b>Pitch</b>	: 5.00 mm
<b>Nominal Rating</b>	: 15A/300V
<b>Dielectric Strength</b>	: > 2kV
<b>Moulded Material</b>	: PA66 - UL94 V0 or V2
<b>Insulation Resistance</b>	: > 1000 M Ω @ 500 Vdc
<b>Terminal</b>	: Tin Plated Copper Alloy
<b>Wire Cage</b>	: Nickel Plated Brass
<b>Screw</b>	: M3 x 0.50 mm : Brass Nickel Plated Suffix "P" : MS Trivalent Zinc Plated Suffix "C"
<b>Wire Size</b>	: 2.5 mm <sup>2</sup>
<b>Maximum Torque</b>	: 0.30 - 0.40 Nm

### ORDERING CODE

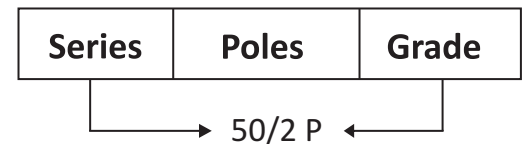

Number of Poles: 2 or 3  
Grade : P or C

P = Professional Grade  
C = Economy Grade

### Approval Data

UL :300V / 12A / 26-14 AWG  
cUL :300V / 12A / 26-14 AWG  
CE :300V / 15A / 26-14 AWG

► The recommended PCB hole diameter is 1.30 mm unless otherwise specified for that product.



Customized Color Options Available  
\*Subject to Minimum Order Quantity

Off/Works: 830/2, GIDC Estate, Makarpura, Vadodara - 390010  
Landline: 9227979806, Telephone: 9227979801  
Email: sales@vitalelectrocomp.com • Web: www.vitalelectrocomp.com

Google Us : Vital Connectors