



Manufacturer of PCB Terminal Blocks, Fuse Holders, Barrier Terminals, & Switches

Screw Type (Cage-Clamp Design) Connectors

Series 45

[Model : 45/2, 45/3]

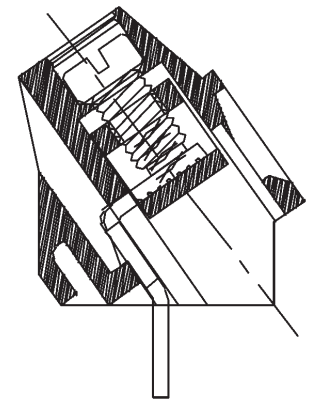
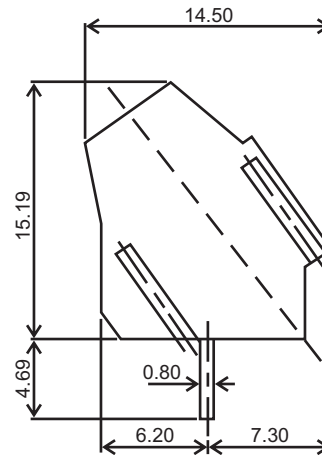
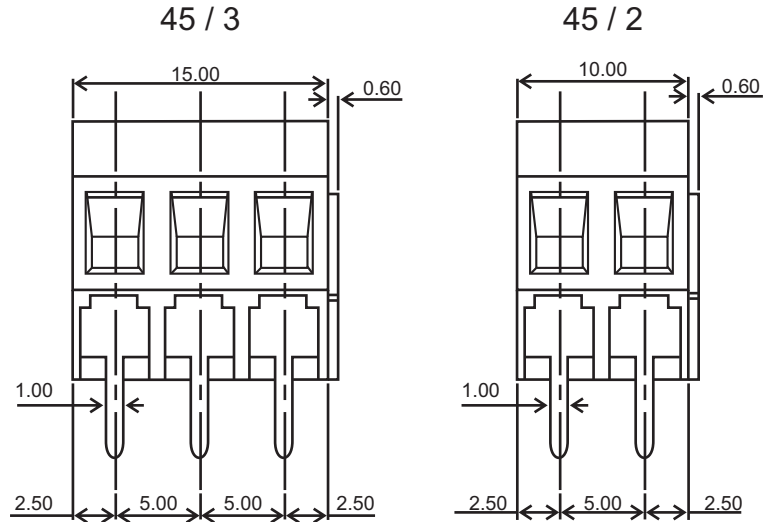
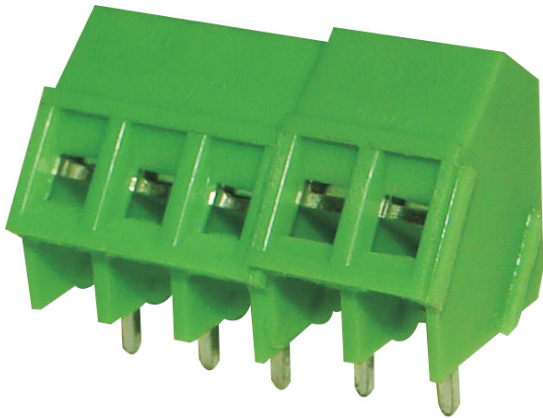

TECHNICAL SPECIFICATIONS :

Pitch	: 5.00 mm
Nominal Rating	: 15A/300V
Dielectric Strength	: > 2kV
Moulded Material	: PA66 - UL94 V0 or V2
Insulation Resistance	: > 1000 M Ω @ 500 Vdc
Terminal	: Tin Plated Copper Alloy
Wire Cage	: Nickel Plated Brass
Screw	: M3 x 0.50 mm : Brass Nickel Plated Suffix "P" : MS Trivalent Zinc Plated Suffix "C"
Wire Size	: 2.5 mm ²
Maximum Torque	: 0.30 - 0.40 Nm

ORDERING CODE

Series	Poles	Grade
--------	-------	-------

→ 45/2 P ←

Number of Poles: 2 or 3

Grade : P or C

P = Professional Grade

C = Economy Grade

Approval Data

UL :300V / 12A / 26-14 AWG

cUL :300V / 12A / 26-14 AWG

CE :300V / 15A / 26-14 AWG

► The recommended PCB hole diameter is 1.30 mm unless otherwise specified for that product.



Off/Works: 830/2, GIDC Estate, Makarpura, Vadodara - 390010

Landline: 9227979806, Telephone: 9227979801

Email: sales@vitalelectrocomp.com • Web: www.vitalelectrocomp.com

Customized Color Options Available
*Subject to Minimum Order Quantity

Google Us : Vital Connectors